



Logitrans
lifting performance



LOGITILT

LT/LTS

ELECTRIC LOGITILT

LOGITILT INOX





Tilter - lift and tilt boxes and crates

The tilter ensures easy access to the contents of crates and boxes - all the way to the bottom - without awkward stretches and strains.

With the tilter, you can lift and transport heavy boxes and crates and tilt them up to a proper angle.

This means you can create ergonomically correct working stations for your employees by ensuring proper working heights and positions - both standing and sitting.

It can be very harmful to perform the same manual task repeatedly, day in and day out, if it requires bending down, reaching out or lifting up. With the 90° tilting function, you can avoid this.

The tilter can be adjusted to meet your specific situation – both in terms of lifting height and tilting degree. These can also be adjusted gradually, as the worker is emptying or loading the box.

Another important feature of the tilter is the movable handle. In

non-moving position, the worker can move the handle to the side to avoid that it blocks the access to the contents. This improves the usability of the machine and efficiency for the worker.

The tilter works well in different industries and working situations, and if you have special needs, we will customise it to match your specific situation 100%

Can lift and tilt boxes and crates up to 90°

Lifting height adjustable to individual requirements

Central location of control buttons and emergency stop

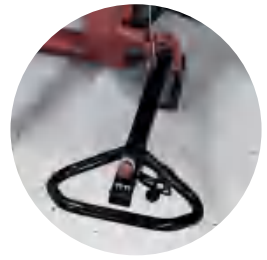

The handle can turn to the side to enable easy operator access

Can be set to stop automatically in the same angle each time



Assisted wheel steering on one wheel



Remote control for tilting and lifting

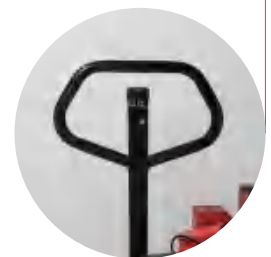

Ergonomically correct handle



Electric tilter

The purpose of the tilter is to create productive and ergonomically correct working stations for employees who need to empty, fill or reach items from boxes and crates.

With the 90° tilting function, the boxes are lifted and positioned without manual efforts, and the worker can easily and efficiently reach the contents - also at the bottom.

The tilting degree can be pre-set, so the tilter stops automatically at a specific angle each time. And with the remote control, the worker can easily adjust the tilting degree and working height during filling or emptying the box.

The tilter is available with electric lifting and tilting, with or without straddle legs.

Important features

The tilter is constructed with several features to improve efficiency, ergonomics and safety at your workplace.

First off, the tilter has a compact design with short overall measures to take up as little space as possible. In addition, ensuring proper working stations without physical exhaustion means more effective processes, less risk of injuries and comfortable and satisfied employees.

The ergonomically designed handle has a lock function, when turned to the side, to ensure safety for the worker, who can access the content without struggling with the handle getting in the way. The remote control enables the worker to adjust tilting degree and lifting height gradually, without having to stop the work.

And finally, the tilter is constructed with foot protectors at the steering wheels, as well as a parking brake.



Logitilt Inox

If you work in wet or hygienic environments, the tilter also comes in stainless steel.

The stainless steel version is designed to avoid bacterial contamination and rust. It is equipped with closed forks for easy cleaning, rounded corners to avoid scratches and is constructed in high quality stainless steel.

The fork chassis is made from AISI 316L acid-resistant steel, and the strong construction of the machine means a long operating life and very low maintenance costs.

*Please refer to our Inox brochure for more information.





Work in practice

The tilter works well across different industries, where big boxes and crates are a part of the daily production. But its function is not limited to this, as we have customers in other industries as well. Some of our customers include:

- Bakeries - to lift and tilt large bowls of dough in bakeries without manual effort.
- Retail/Goodwill recycling store - Emptying out bins.
- Postal Service/USPS - Handling crates for COVID tests.
- Hospitals/healthcare - Custom hospital bed tilter for cleaning and maintenance.

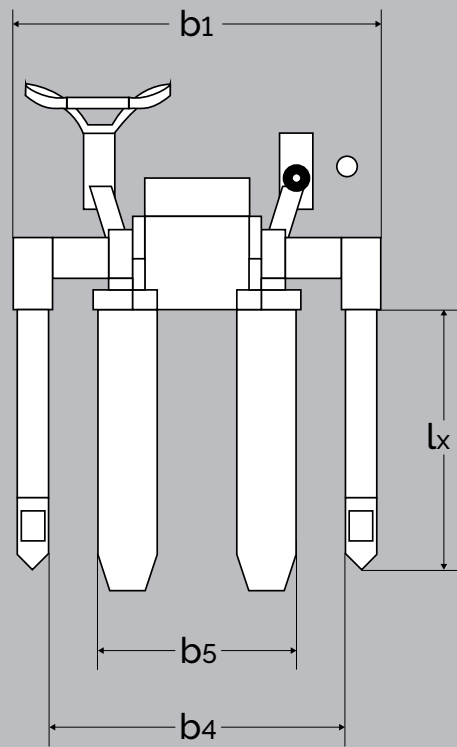
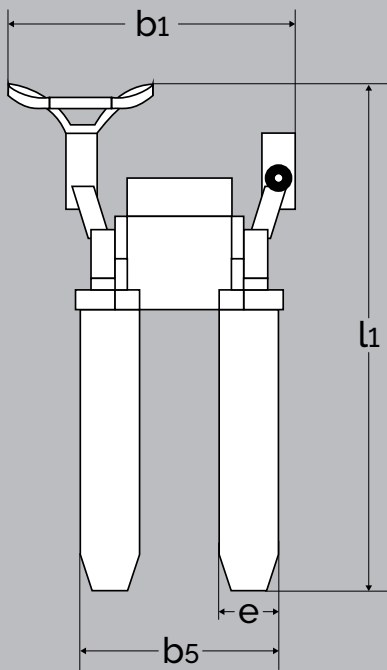
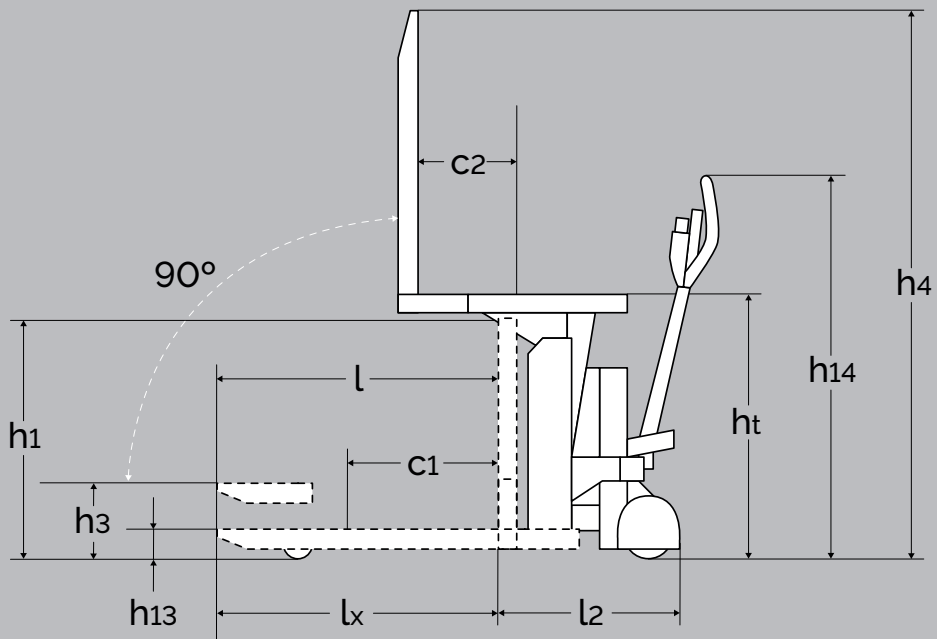

PRODUCT
(measured in mm)

LT 1001

LTS 1001

SPECIFICATIONS - LOGITILT LT + LTS

Capacity in kg		1000*	
Height, tilted	h_t	750-950	
Lifting height	h_3	275	
Fork length	l	800/1150	
Overall height with handle	h_{14}	1055	
Overall height	h_1	680	
Overall width	b_1	780	$166 + b_4$
Fork span	b_5	560/680	
Fork width	e	163	
Overall length by 800 mm forks	l_1	1425	
Length without forks	l_2	590	
Run-in length	l_{1x}	712	735
Overall height	h_4	$h_t + l$	
Lowered height	h_{13}	85	
Load centre	c_1	max $l/2$	
Load centre	c_2	min 200 - max 420	
Width between legs	b_4	316/436	850-942/942-1124/1124-1306
Pump motor		0,8 KW 12V	
Lifting speed lift/tilt		4 s/14 s	
Lowering speed lift/tilt		3 s/11 s	
Weight by 800 mm forks (without battery)		177 kg	251 kg



Ergonomic Lifting Equipment

Logitrans A/S

+45 76 88 16 00

info@logitrans.com

www.logitrans.com

