

PJD-700

For reference only

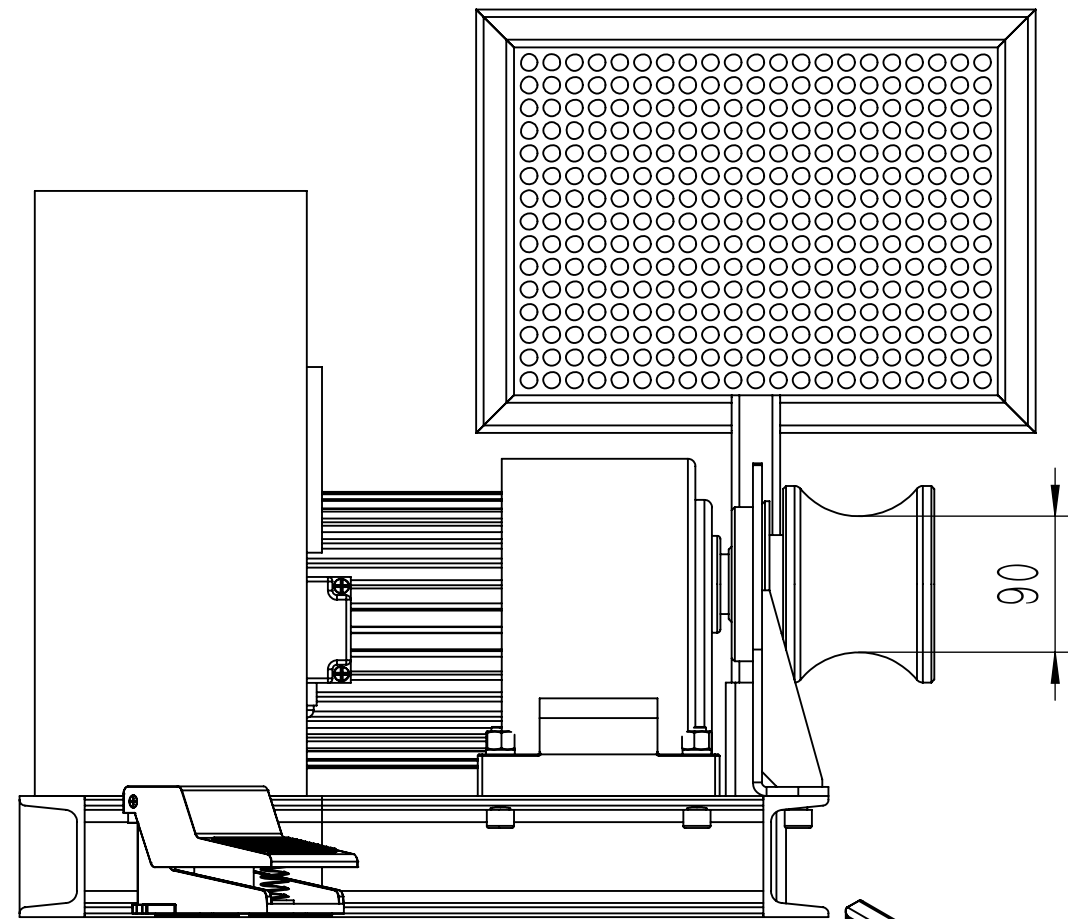

Foot control switch

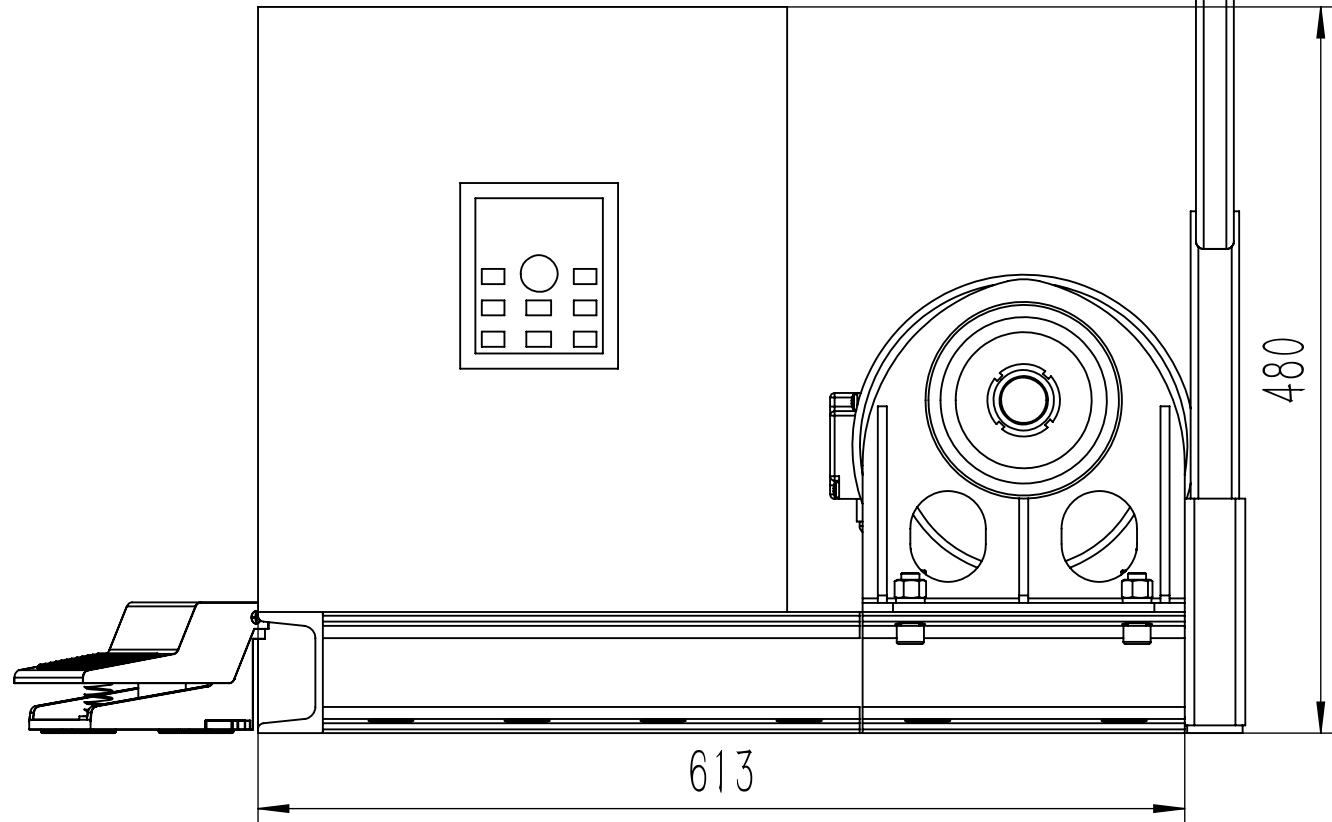
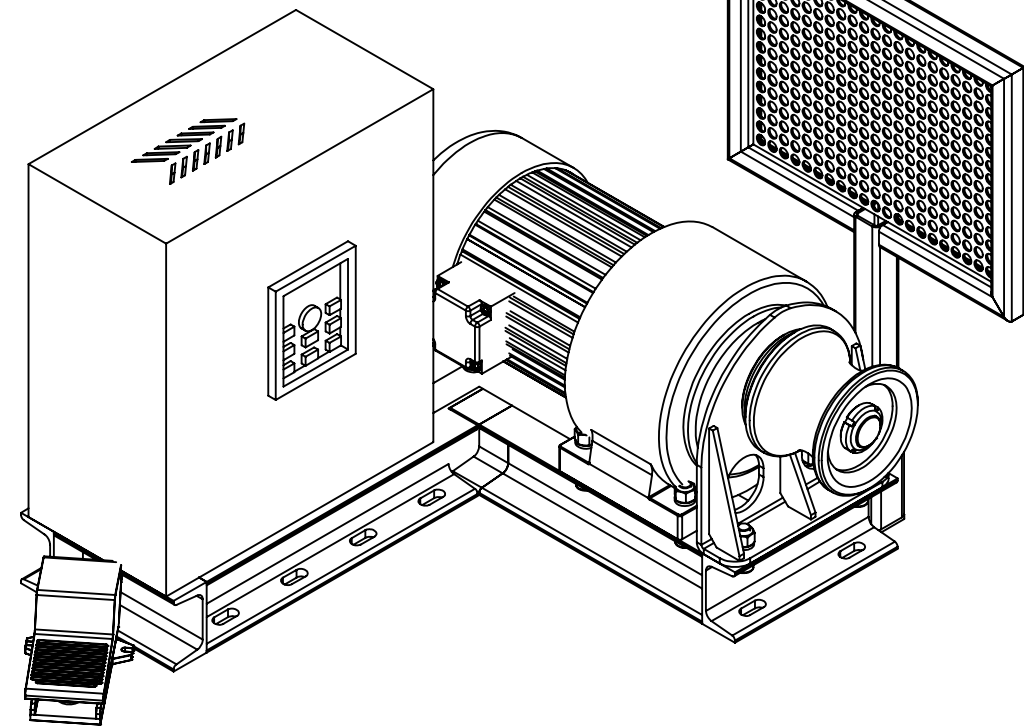
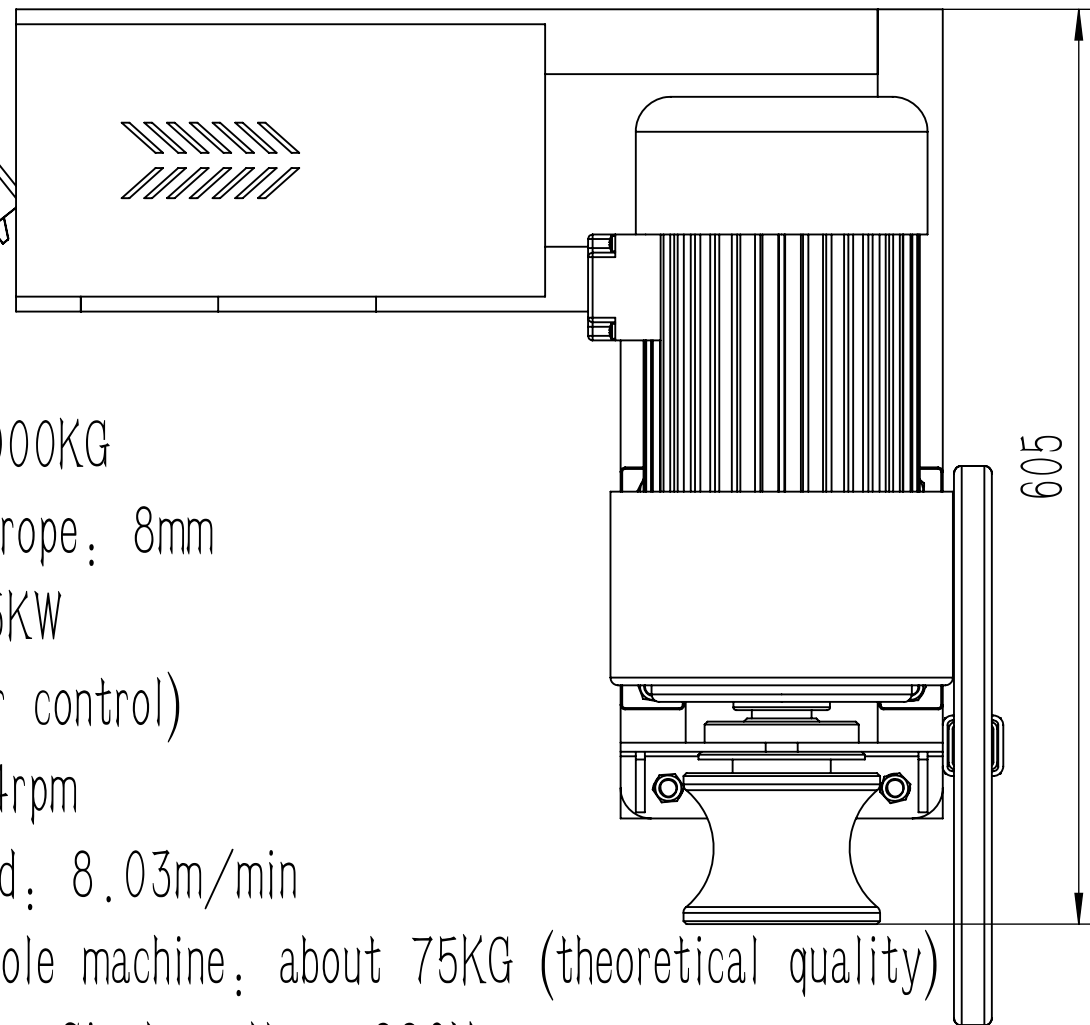
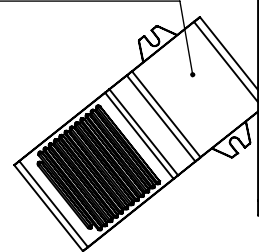

parameter

1. Rated tension: 2000KG
2. Diameter of wire rope: 8mm
3. Motor power: 1.5KW
(frequency converter control)
4. Drum speed: 28.4rpm
5. Average rope speed: 8.03m/min
6. Quality of the whole machine: about 75KG (theoretical quality)
7. Input power supply: Single voltage 220V

Mark	Nos	Section	Document NO.	Signature	Date	Design mark	Weight	Scale	Cable winch PJD-700
Design			Standard					1:5	
Check			Craft						
Supervisor			Audit						
Design			Authorize			Total: 1	Page: 1	Version:	Substitute:

Part number
General document registration
Trace
Sketching
Old base map total number
Base map total number
Signature
Date