

ENGINEERED LIFTING SOLUTIONS

HOISTING FOR EXTREME APPLICATIONS



**MANUAL CHAIN HOIST ATEX
MEDIUM**

500 KG – 50,000 KG LIFTING CAPACITY



**ATEX
Explosion Protected**

Leaflet No. KITO-86812:01

MANUAL CHAIN HOIST ATEX MEDIUM

500 KG – 50,000 KG LIFTING CAPACITY



ATEX
Explosion Protected

Designed and manufactured according to:

- ▶ EC machinery directive 2006/42/EC
ATEX Directive 2014/34/EU
- ▶ EN13157
- ▶ Manufactured in the Netherlands

Standard features:

- ▶ Equipment classification Gas Ex II 2G EX h IIB T3 Gb (zone 1)
- ▶ Equipment classification Dust Ex II 2D EX h IIIB T200°C Db (zone 21)
- ▶ Impact resistant housing
- ▶ Double pawl spring
- ▶ Highly accurate and durable gear mechanism
- ▶ Double brake enclosure keeping out rainwater and dust
- ▶ Mechanical load brake
- ▶ Low pulling force on the hand chain
- ▶ Nickel plated load chain, grade V (G 100) in acc. with standard EN818-7
- ▶ Hand chain electric galvanized
- ▶ Surface treatment power coating, colour Munsell 6YR6/14R
- ▶ Operation temperature -40°C / +40°C
- ▶ Overload protection by slipping clutch

Optional:

- ▶ Available in equipment class Gas Ex II 2G EX h IIC T3 Gb (zone 1)
- ▶ Available in equipment class Dust Ex II 2D EX h IIIC T135°C Db (zone 21)
- ▶ Temperature class T4 / T135°C will be observed separately for each project
- ▶ Special surface protection acc. to ISO 12944.
- ▶ Excellent combination with HD3C Explosion protected trolleys
- ▶ Canvas chain bag
- ▶ 3.1 certificate load test certificate
- ▶ Steel or stainless steel container
- ▶ Stainless steel 316 load chain and hand chain
- ▶ Stainless steel nameplate with tag number

Explosion Protected:

Equipment is executed with non-sparking materials for fast mechanical contact parts for hand chain movements and internal fast moving hoist parts, extended with unique and reliable bronze coated load hooks.

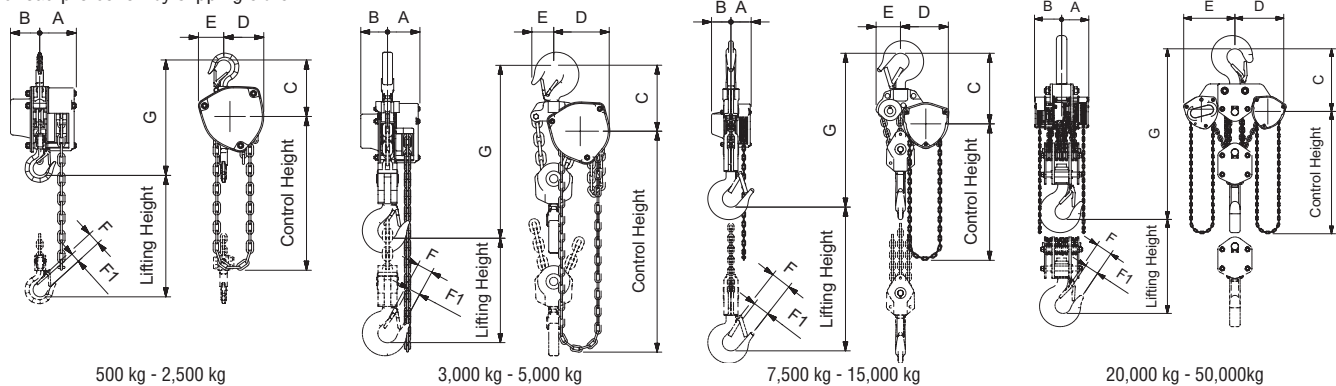

Capacity kg	Article number	Model	No. of falls	Chain Size mm	Max. pulling force kg	Weight 3 meters Lift kg	Headroom mm	Dimensions					
								A	B	D	E	F	F1
500	86812-00500	K005	1	5	24	10	285	89	69	99	62	31,1	27
1,000	86812-01000	K010	1	6,3	29	11,5	295	91	71	99	62	34,6	29
1,500	86812-01500	K015	1	7,1	35	14,5	350	93	78	112	70	38,8	34
2,000	86812-02000	K020	1	8	36	20	375	95	87	125	77	40	36
2,500	86812-02500	K025	1	9	33	27	420	101	91	143	90	42,5	40
3,000	86812-03000	K030	2	7,1	36	24	510	93	78	162	73	46	42,5
5,000	86812-05000	K050	2	9	34	41	600	101	91	194	88	50	46,5
7,500	86812-07500	K075	3	9	35	60	770	101	91	253	120	79,5	72,5
10,000	86812-10000	K100	4	9	36	79	760	81	111	308	130	79,2	72,5
15,000	86812-15000	K150	6	9	37	149	1020	149	119	337	155	94,6	80
20,000	86812-20000	K200	8	9	36x2	227	1180	187	187	373	373	95,7	81
30,000	86812-30000	K300	10	9	43x2	300	1300	202	202	373	373	118	103
40,000	86812-40000	K400	14	9	43x2	467	1480	251	251	380	380	108	96
50,000	86812-50000	K500	16	9	49x2	625	1560	272	272	398	398	118	100

Changes in design and measurements reserved.